

STATE	PROJECT NO.	SHEET NO.	TOTAL SHEETS
	2021CPT.10.17.10601		
F.A. PROJECT NO.			



ENLARGED MUNICIPAL AND SUBURBAN AREAS

MECKLENBURG COUNTY

NORTH CAROLINA

PREPARED BY THE
NORTH CAROLINA DEPARTMENT OF TRANSPORTATION
DIVISION OF HIGHWAYS - DIVISION 10 DISTRICT 2

MAP 1 NC 24/27 ALBEMARLE ROAD EBL
0.51 MILES
FROM SR 5223 WILGROVE-MINT HILL ROAD
TO RXR BRIDGE

MAP 2 NC 24/27 ALBEMARLE ROAD WBL
0.48 MILES
FROM RXR BRIDGE
TO SR 5223 WILGROVE-MINT HILL ROAD

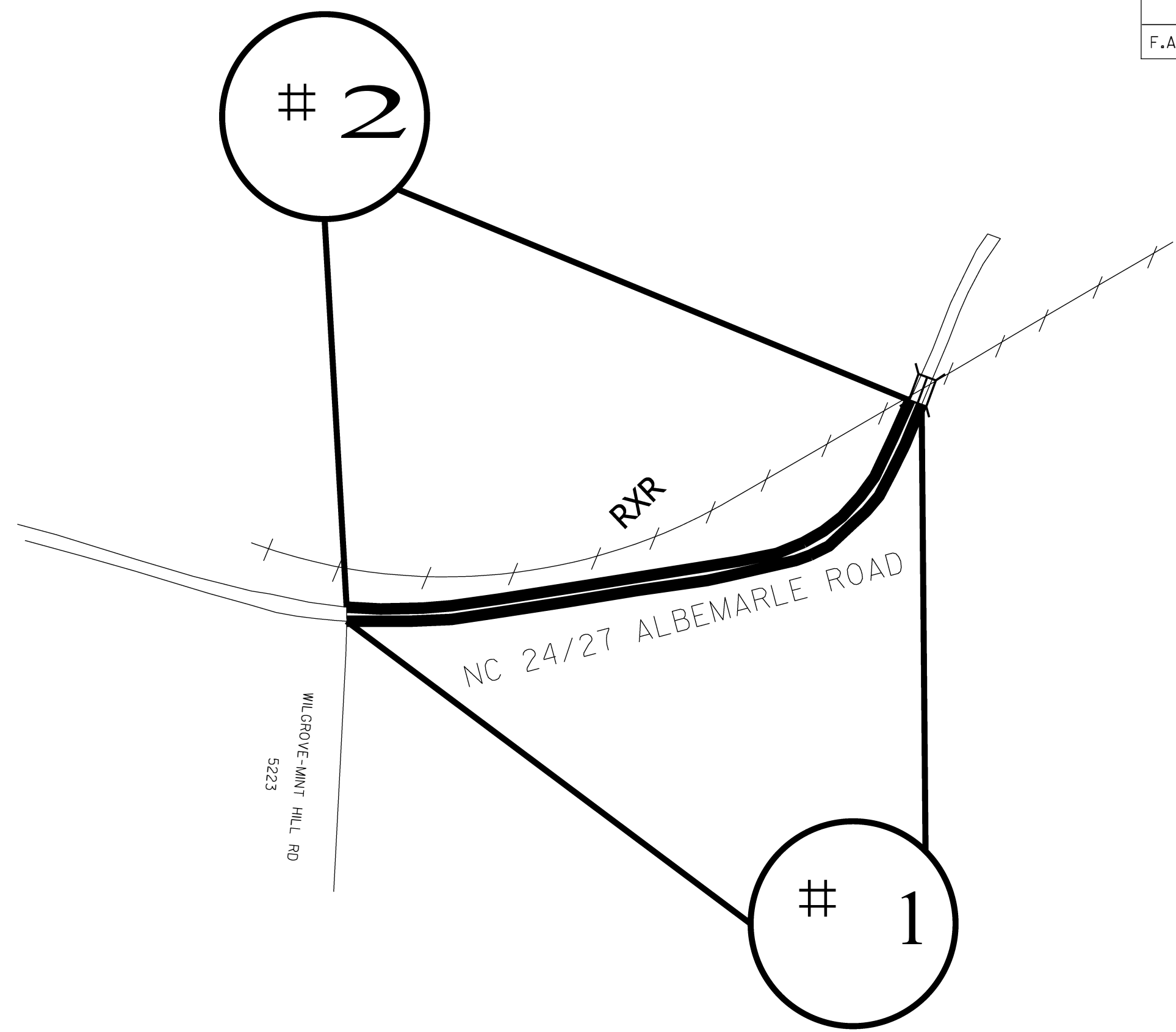

STATE	PROJECT NO.	SHEET NO.	TOTAL SHEETS
	2021CPT.10.17.10601	2	
F.A. PROJECT NO.			

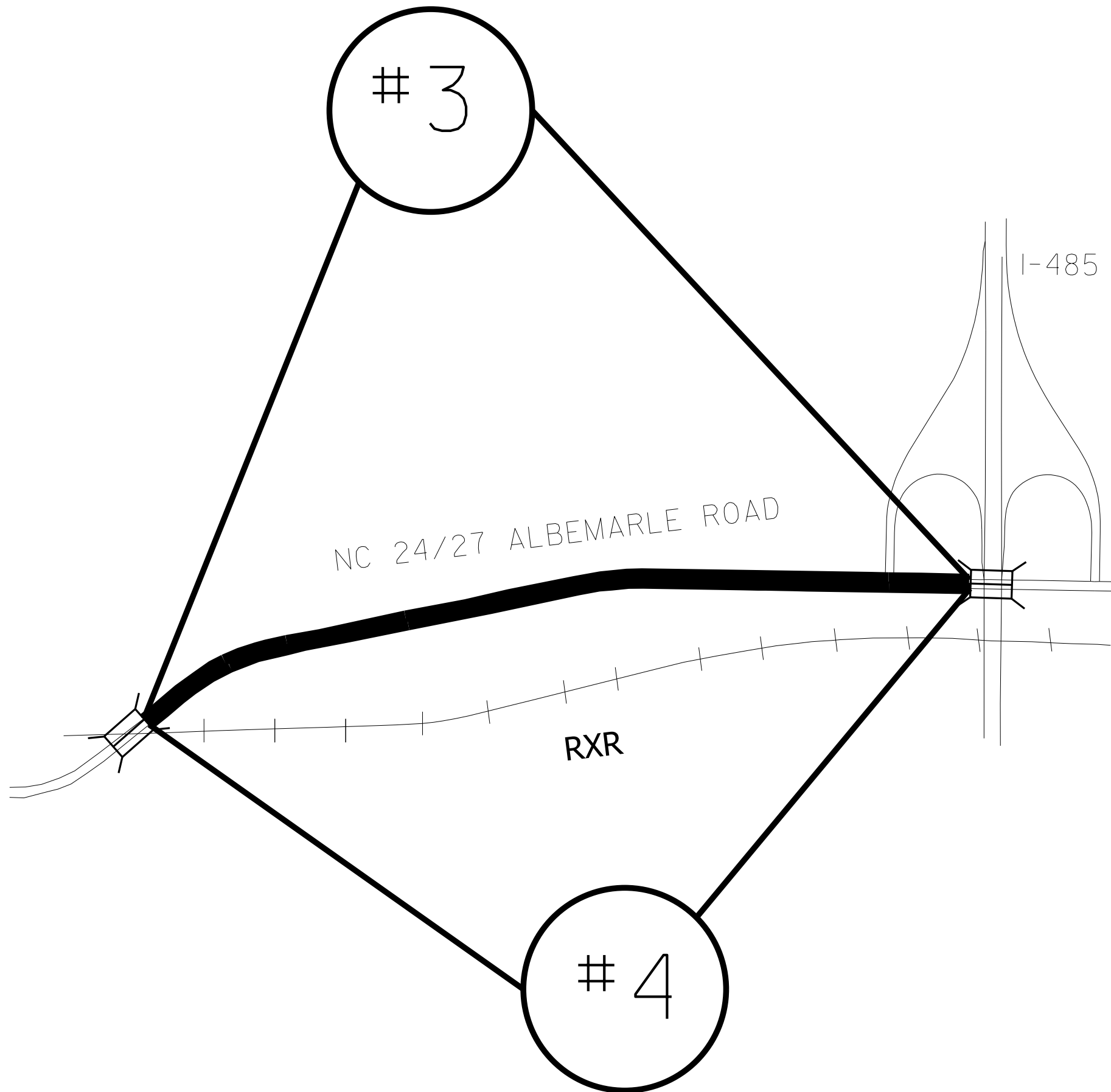

ENLARGED MUNICIPAL AND SUBURBAN AREAS
MECKLENBURG COUNTY
 NORTH CAROLINA
PREPARED BY THE
 NORTH CAROLINA DEPARTMENT OF TRANSPORTATION
 DIVISION OF HIGHWAYS - DIVISION 10 DISTRICT 2

MAP# 3 NC 24/27 ALBEMARLE ROAD WBL
 0.94 MILES
 FROM RXR BRIDGE
 TO I-485 BRIDGE

MAP# 4 NC 24/27 ALBEMARLE ROAD EBL
 0.94 MILES
 FROM I-485 BRIDGE
 TO RXR BRIDGE

STATE	PROJECT NO.	SHEET NO.	TOTAL SHEETS
	2021CPT.10.17.20601	3	
F.A. PROJECT NO.			



ENLARGED MUNICIPAL AND SUBURBAN AREAS

MECKLENBURG COUNTY

NORTH CAROLINA

PREPARED BY THE
NORTH CAROLINA DEPARTMENT OF TRANSPORTATION
DIVISION OF HIGHWAYS - DIVISION 10 DISTRICT 2

MAP 5 SR 2828 ROCKY RIVER ROAD
0.56 MILES

FROM THE PAVT JOINT .06 MILES EAST OF
BACK CREEK CHURCH RD TO THE PAVT JOINT
.05 MILES WEST OF MORTON HALL ROAD.

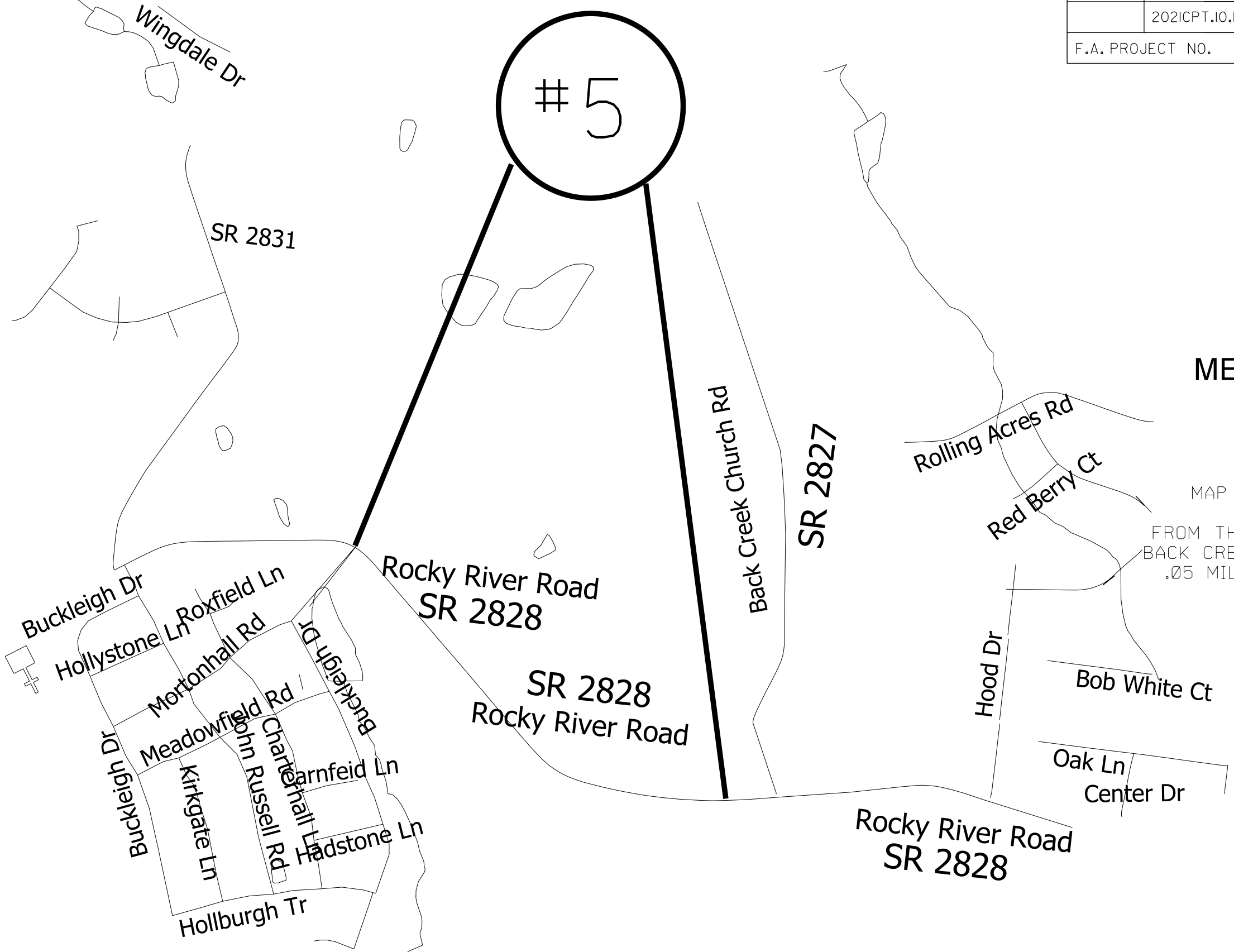

STATE	PROJECT NO.	SHEET NO.	TOTAL SHEETS
	2021CPT.10.17.20601	4	
F.A. PROJECT NO.			



ENLARGED MUNICIPAL AND SUBURBAN AREAS

MECKLENBURG COUNTY

NORTH CAROLINA

PREPARED BY THE
NORTH CAROLINA DEPARTMENT OF TRANSPORTATION
DIVISION OF HIGHWAYS - DIVISION 10 DISTRICT 2

MAP 6 SR 2148 NANTZ RD
0.79 MILES
FROM THE PAVT JOINT .26 MILES
WEST OF SR 5544 WEST CATAWBA AVE
TO EOM

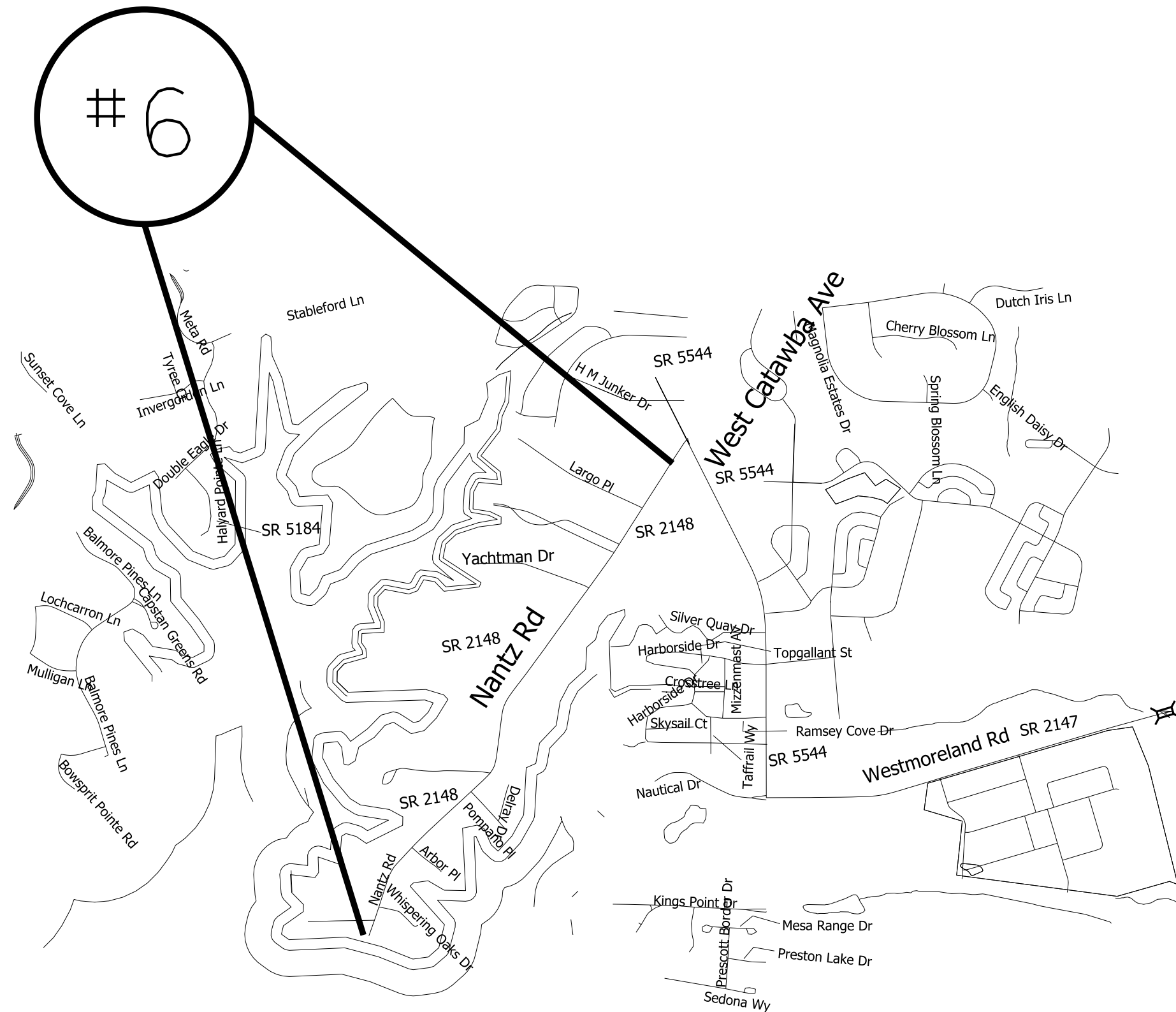

STATE	PROJECT NO.	SHEET NO.	TOTAL SHEETS
N.C.	2021CPT.10.17.10601 2021CPT.10.17.20601	5	
F.A. PROJECT NO.			

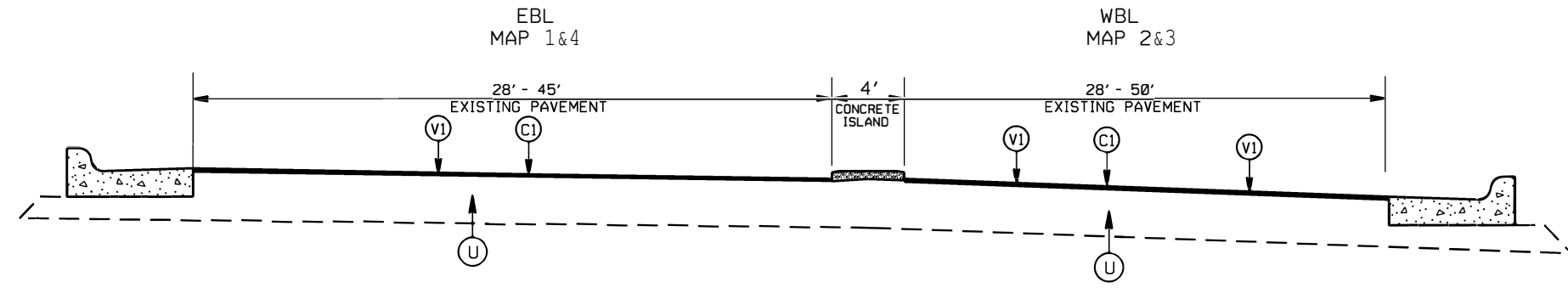

TYPICAL SECTION NO. 1

NC 24/27 ALBEMARLE ROAD EBL (MAP 1)
 NC 24/27 ALBEMARLE ROAD WBL (MAP 2)
 NC 24/27 ALBEMARLE ROAD WBL (MAP 3)
 NC 24/27 ALBEMARLE ROAD EBL (MAP 4)

PAVEMENT SCHEDULE

(C1)	PROP. APPROX. 1.5" ASPHALT CONC. SURFACE COURSE, TYPE S9.5C, AT AN AVERAGE RATE OF 168 LBS. PER SQ. YD.
(T1)	SHOULDER RECONSTRUCTION
(U)	EXISTING PAVEMENT
(V1)	MILL EXISTING ASPHALT PAVEMENT, 1.5" DEPTH.
(V3)	PROFILE MILL EXISTING PAVEMENT, 0 - 1.5" DEPTH.
(W)	CONCRETE BRIDGE DECK

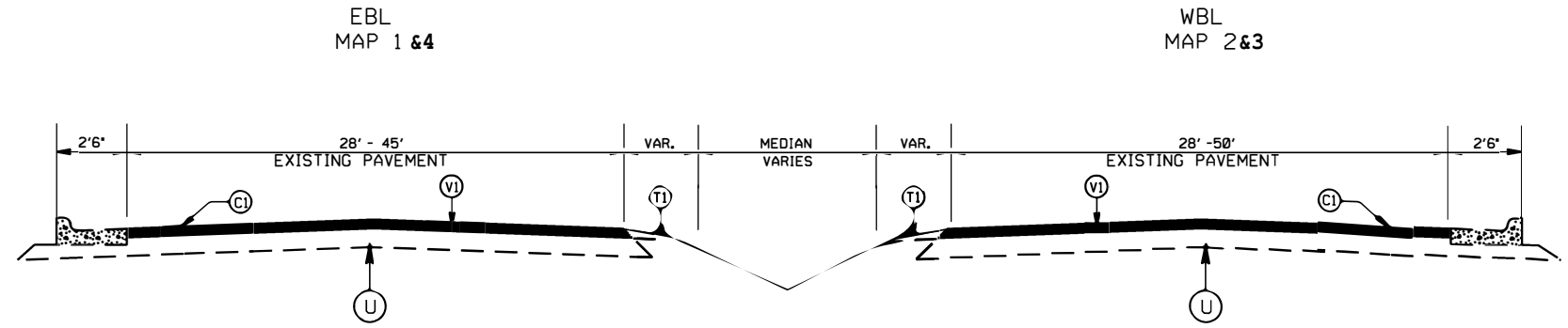

TYPICAL SECTION NO. 2

NC 24/27 ALBEMARLE ROAD EBL (MAP 1)
 NC 24/27 ALBEMARLE ROAD WBL (MAP 2)
 NC 24/27 ALBEMARLE ROAD WBL (MAP 3)
 NC 24/27 ALBEMARLE ROAD EBL (MAP 4)

2021-2022
MECKLENBURG COUNTY RESURFACING

SCALE	-NA-		REVISIONS
DATE	1/21		
DWG. BY	AMO		
DESIGN BY	AMO		
APPROVED	CLA		

STATE	PROJECT NO.	SHEET NO.	TOTAL SHEETS
N.C.	2021CPT.10.17.10601 2021CPT.10.17.20601	6	
F.A. PROJECT NO.			

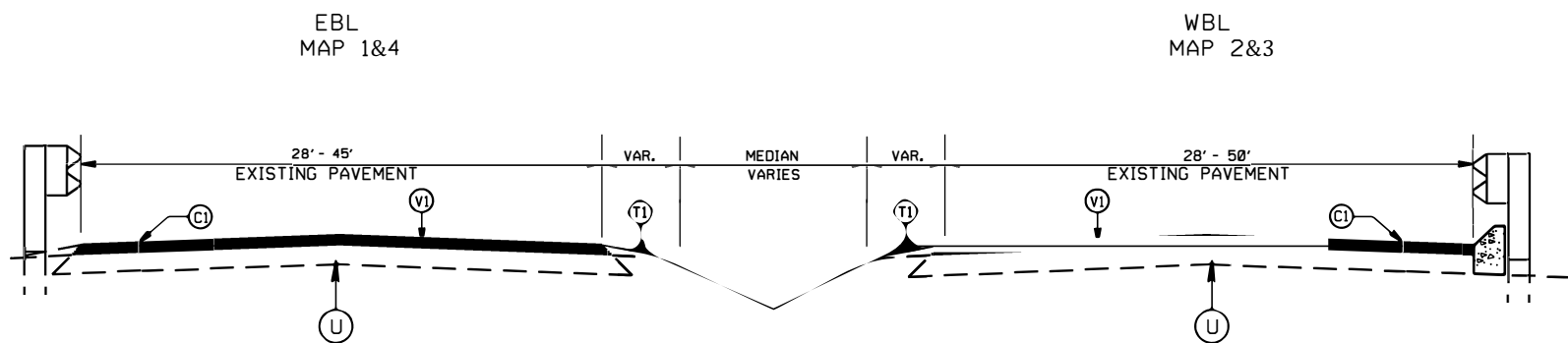

TYPICAL SECTION NO. 3

- NC 24/27 ALBEMARLE ROAD EBL (MAP 1)
- NC 24/27 ALBEMARLE ROAD WBL (MAP 2)
- NC 24/27 ALBEMARLE ROAD WBL (MAP 3)
- NC 24/27 ALBEMARLE ROAD EBL (MAP 4)

PAVEMENT SCHEDULE

(C1)	PROP. APPROX. 1.5" ASPHALT CONC. SURFACE COURSE, TYPE S9.5C, AT AN AVERAGE RATE OF 168 LBS. PER SQ. YD.
(T1)	SHOULDER RECONSTRUCTION
(U)	EXISTING PAVEMENT
(V1)	MILL EXISTING ASPHALT PAVEMENT, 1.5" DEPTH.
(V3)	PROFILE MILL EXISTING PAVEMENT, 0 - 1.5" DEPTH.
(W)	CONCRETE BRIDGE DECK

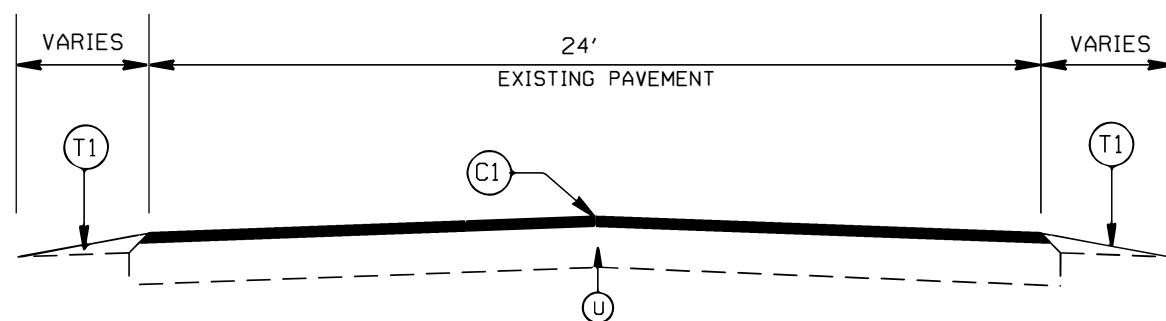

TYPICAL SECTION NO. 4

SR 2828 ROCKY RIVER ROAD (MAP 5)

2021-2022
MECKLENBURG COUNTY RESURFACING

SCALE	-NA-
DATE	1/21
DWG. BY	AMO
DESIGN BY	AMO
APPROVED	CLA



REVISIONS	

STATE	PROJECT NO.	SHEET NO.	TOTAL SHEETS
N.C.	2021CPT.10.17.10601 2021CPT.10.17.20601	7	
F.A. PROJECT NO.			

PAVEMENT SCHEDULE

(C1)	PROP. APPROX. 1.5" ASPHALT CONC. SURFACE COURSE, TYPE S9.5C, AT AN AVERAGE RATE OF 168 LBS. PER SQ. YD.
(T1)	SHOULDER RECONSTRUCTION
(U)	EXISTING PAVEMENT
(V1)	MILL EXISTING ASPHALT PAVEMENT, 1.5" DEPTH.
(V3)	PROFILE MILL EXISTING PAVEMENT, 0 - 1.5" DEPTH.
(W)	CONCRETE BRIDGE DECK

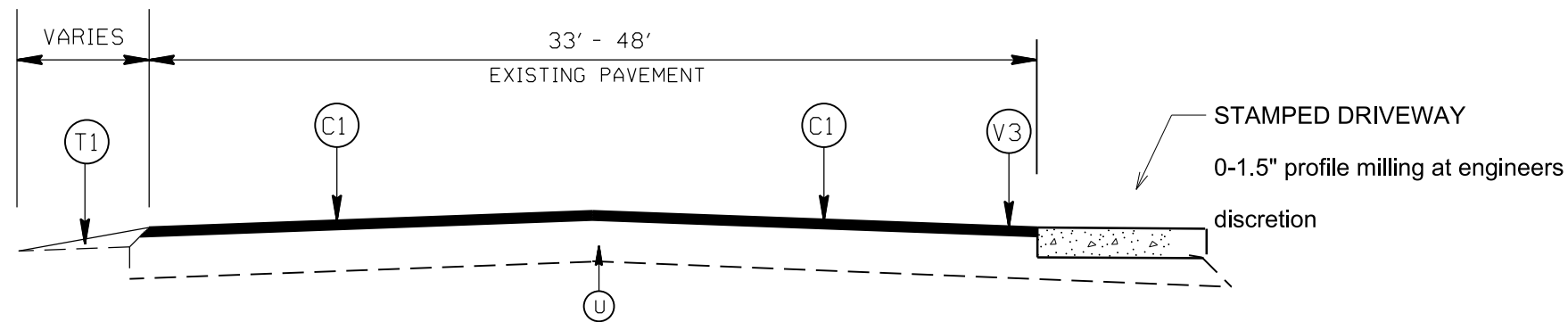

TYPICAL SECTION NO. 5
SR 2148 NANTZ ROAD (MAP 6)

2021-2022
MECKLENBURG COUNTY RESURFACING

SCALE	-NA-		REVISIONS
DATE	1/21		
DWG. BY	AMO		
DESIGN BY	AMO		
APPROVED	CLA		

STATE	PROJECT NO.	SHEET NO.	TOTAL SHEETS
N.C.	2021CPT.10.17.10601 2021CPT.10.17.20601	8	
F.A. PROJECT NO.			

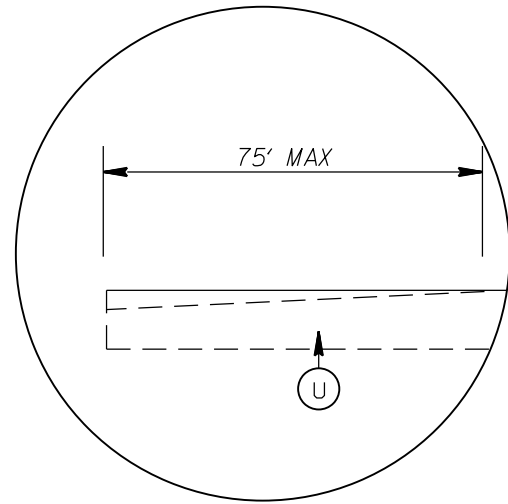

DETAIL FOR INCIDENTAL MILLING (0" TO 1.5")

TIE-IN

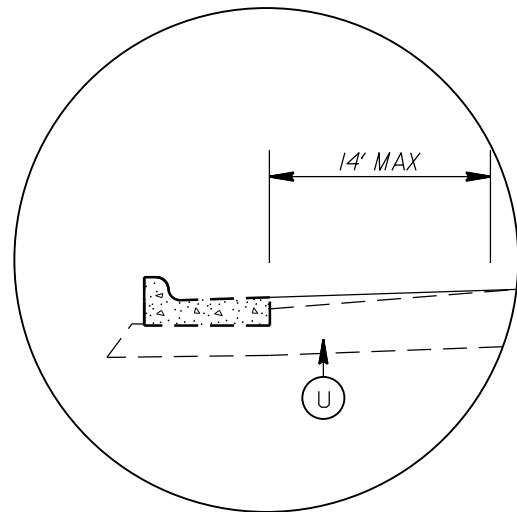

DETAIL FOR PROFILE MILLING (0- 1.5")

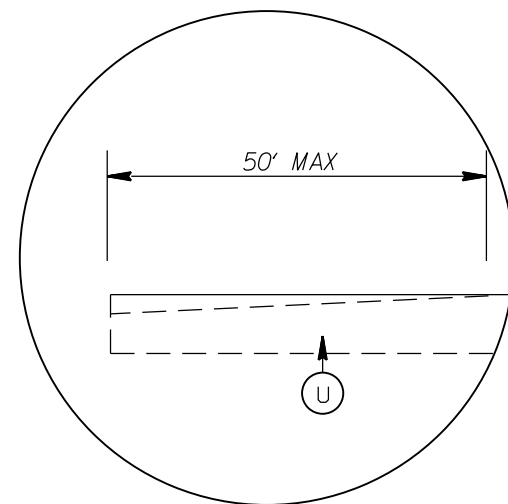

DETAIL FOR INCIDENTAL MILLING (0" TO 1.0")

TIE-IN

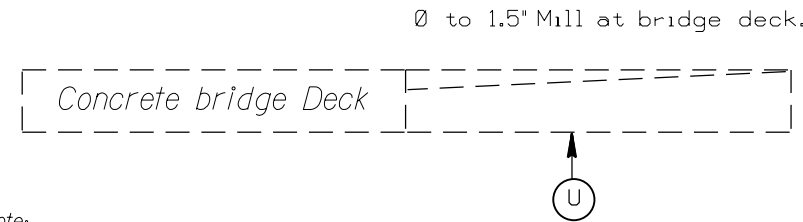

Note:
1. Milling shall be performed at the bridge approaches as directed by the Engineer, in accordance with this detail.

PATCHING DETAIL

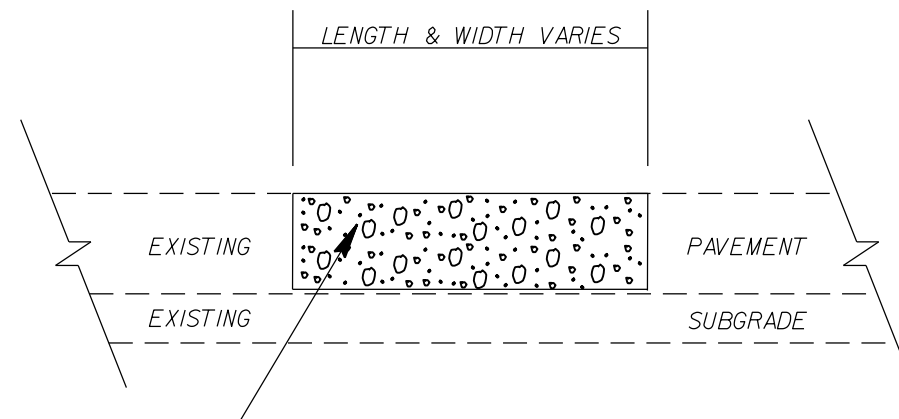

RATE IS VARIABLE AND SHALL BE AS DIRECTED BY THE ENGINEER. ASPHALT TYPE 119.0C SHALL BE PLACED.

PAVEMENT SCHEDULE

(C1)	PROP. APPROX. 1.5" ASPHALT CONC. SURFACE COURSE, TYPE S9.5C, AT AN AVERAGE RATE OF 168 LBS. PER SQ. YD.
(T1)	SHOULDER RECONSTRUCTION
(U)	EXISTING PAVEMENT
(V1)	MILL EXISTING ASPHALT PAVEMENT, 1.5" DEPTH.
(V3)	PROFILE MILL EXISTING PAVEMENT, 0 - 1.5" DEPTH.
(W)	CONCRETE BRIDGE DECK

2021-2022
MECKLENBURG COUNTY RESURFACING

SCALE	-1A-		REVISIONS	
DATE	1/21			
DWG. BY	AMO			
DESIGN BY	AMO			
APPROVED	CLA			

NOTES:

- 1) DETAIL DOES NOT APPLY TO OGAFB AND ULTRA-THIN BONDED WEARING COURSE.
- 2) BACKFILL SHOULDER WITH APPROVED MATERIAL.
- 3) THE SHOULDER WEDGE DEVICE MAY BE DISENGAGED AT PAVED DRIVEWAYS AND SIDE STREETS.

STATE	PROJECT NO.	SHEET NO.	TOTAL SHEETS
	2021CPT.10.17.10601 2021CPT.10.17.20601	9	
F.A. PROJECT NO.			

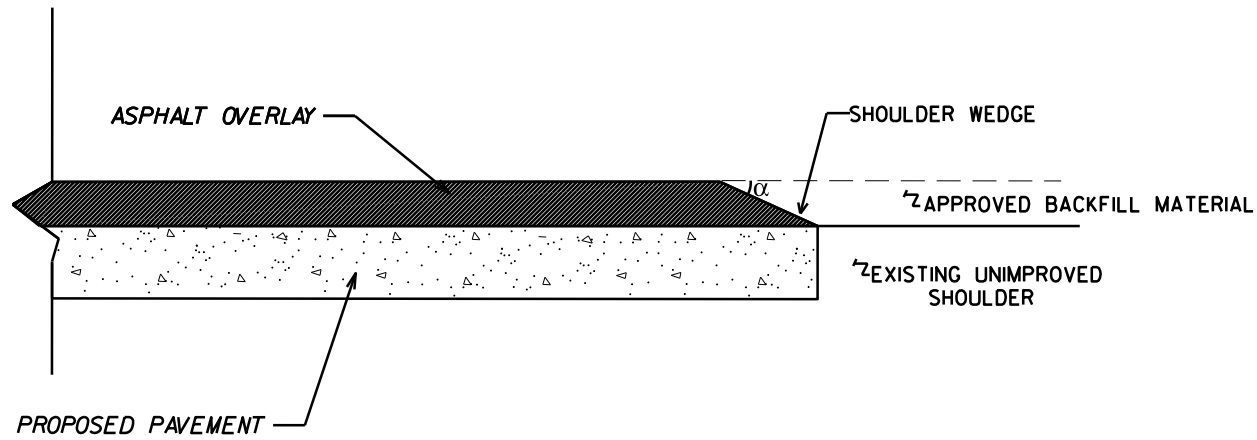

SHOULDER WEDGE DETAIL

(RESURFACING PROJECTS W/ WIDENING OR WITH EXISTING PAVED SHOILDER HAVING NO DROPOFFS)

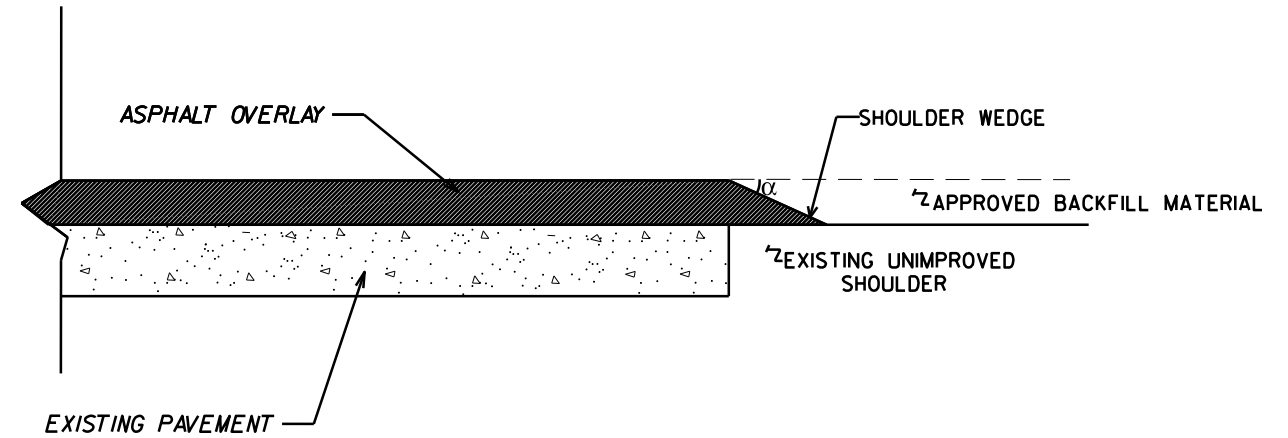

SHOULDER WEDGE DETAIL

(RESURFACING PROJECTS W/ NO WIDENING)

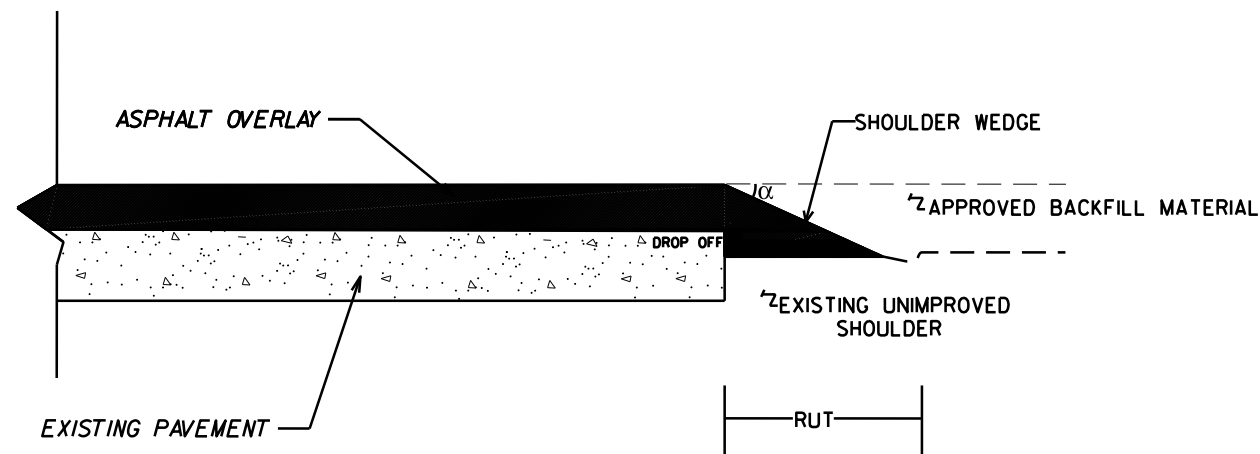

SHOULDER WEDGE DETAIL
(RESURFACING ADJACENT TO RUTTED SHOULDER)

$\alpha = 30$ DEGREES

SHOULDER WEDGE DETAILS			
SCALE	-NA-		REVISIONS
DATE	01/21		
DWG. BY	AMO		
DESIGN BY	AMO		
APPROVED	CLA		

URBAN / SUBURBAN WORKZONES

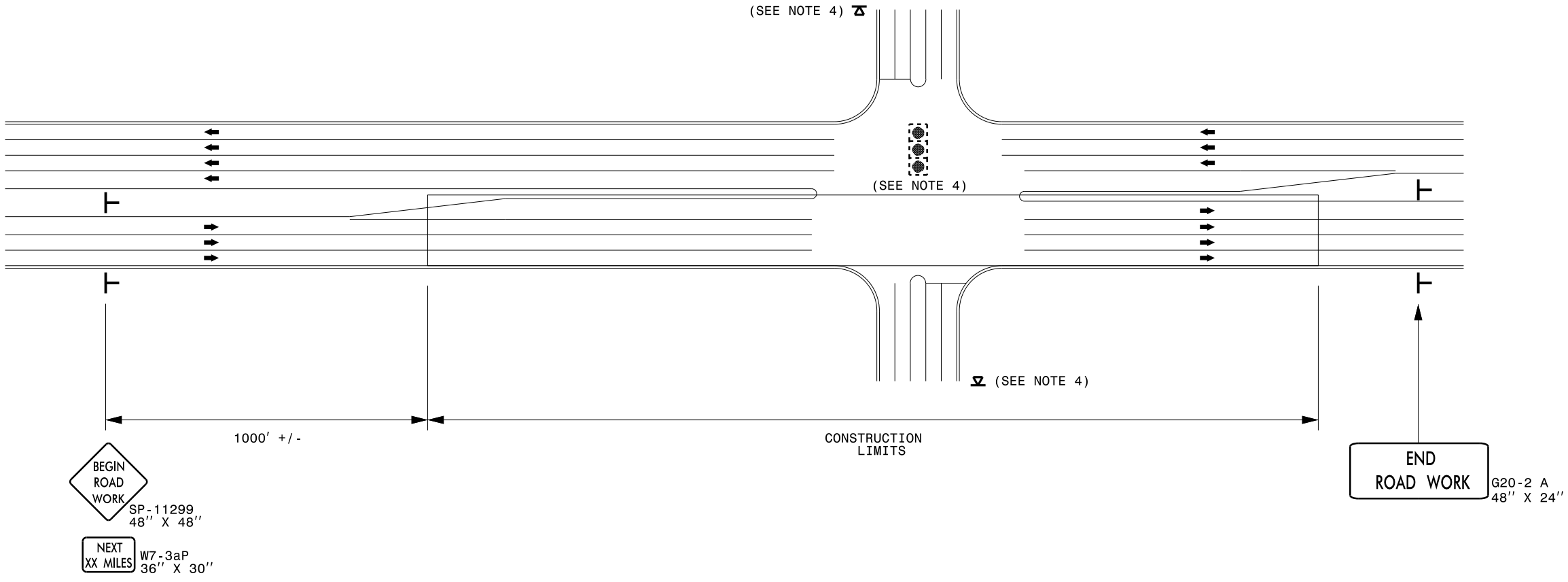

NOTES:

- 1) 48" x 48" SIZED SIGNS (SP- 11299) MAY BE REDUCED TO 36" X 36" ON ROADWAYS WITH SPEED LIMITS OF 40 MPH OR LESS.
- 2) MOUNT SIGNS THAT ARE LARGER THAN 10 SQUARE FEET IN AREA ON TWO OR MORE WOOD OR U-CHANNEL SUPPORTS. PERFORATED SQUARE TUBING SUPPORT SYSTEMS MAY SUPPORT LARGER AREAS ON A SINGLE SUPPORT. FOLLOW MANUFACTURER'S RECOMMENDATIONS. THESE SYSTEMS SHALL BE NCHRP 350 COMPLIANT AND NCDOT APPROVED.
- 3) ADVANCE WARNING SIGNS NOT REQUIRED ON NON-SIGNALIZED SIDE STREETS.
- 4) MAY USE LAW ENFORCEMENT TO CONTROL TRAFFIC AT SIGNALIZED INTERSECTIONS AS DIRECTED BY THE ENGINEER. PROVIDE PORTABLE "ROAD WORK AHEAD" (W20-1) SIGNS 500' IN ADVANCE ALONG BOTH APPROACHES FROM THE SIDE STREETS WHEN PAVING PROCEEDS THROUGH THE INTERSECTION.
- 5) LATERAL CLEARANCE AT ALL SIGN LOCATIONS SHALL BE 2' AS MEASURED FROM THE EDGE OF PAVEMENT OR THE FACE OF THE CURB. WHEN UNABLE TO OBTAIN THE LATERAL CLEARANCE WITHIN THE MEDIAN AREA USE SHOULDER MOUNTS ONLY.
- 6) SIGN MOUNT LOCATIONS SHALL NOT BLOCK SIDEWALKS OR DRIVEWAYS.
- 7) IF STATIONARY GENERAL WARNING SIGNS ARE USED, THEY WILL BE PAID FOR PER SECTION 104 OF THE NCDOT STANDARD SPECIFICATIONS AS EXTRA WORK.
- 8) IF MILLED AREAS ARE NOT PAVED BACK BY THE END OF THE WORK DAY, PORTABLE SIGNS SHALL BE USED TO WARN DRIVERS OF THE PRESENT CONDITIONS. THESE ARE TO INCLUDE, BUT NOT LIMITED TO "ROUGH ROAD" W8-8, "UNEVEN LANES" W8-11, "GROOVED PAVEMENT" W8-15 w/MOTORCYCLE PLAQUE MOUNTED BELOW. THESE ARE TO BE DOUBLE INDICATED ON MULTI-LANE ROADWAYS WITH SPEED LIMITS 45 MPH AND GREATER WHERE LATERAL CLEARANCE CAN BE OBTAINED WITHIN THE MEDIAN AREAS. THESE PORTABLE SIGNS ARE INCIDENTAL TO THE OTHER ITEMS OF WORK INCLUDED IN THE TEMPORARY TRAFFIC CONTROL (LUMP SUM) PAY ITEM.

LEGEND	
T	STATIONARY SIGN
➔	DIRECTION OF TRAFFIC FLOW



**RESURFACING ADVANCE
WARNING SIGNS FOR
URBAN / SUBURBAN
FACILITIES**

21-APR-2021 15:25
 C:\Users\bdhill\Documents\June 2021 Resurfacing\Mecklenburg_Typicals Round 2.dgn
 bdhill AT DIVID-303607L

SIGNING FOR RESURFACING PROJECTS

LEGEND
 STATIONARY SIGN
 DIRECTION OF TRAFFIC FLOW

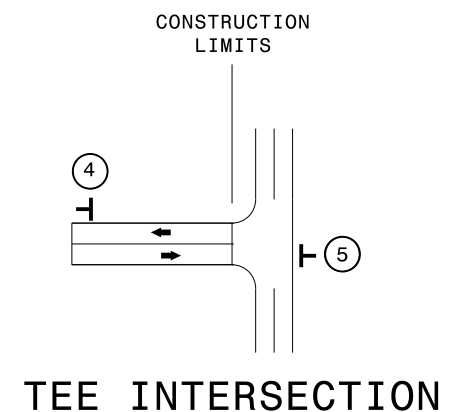
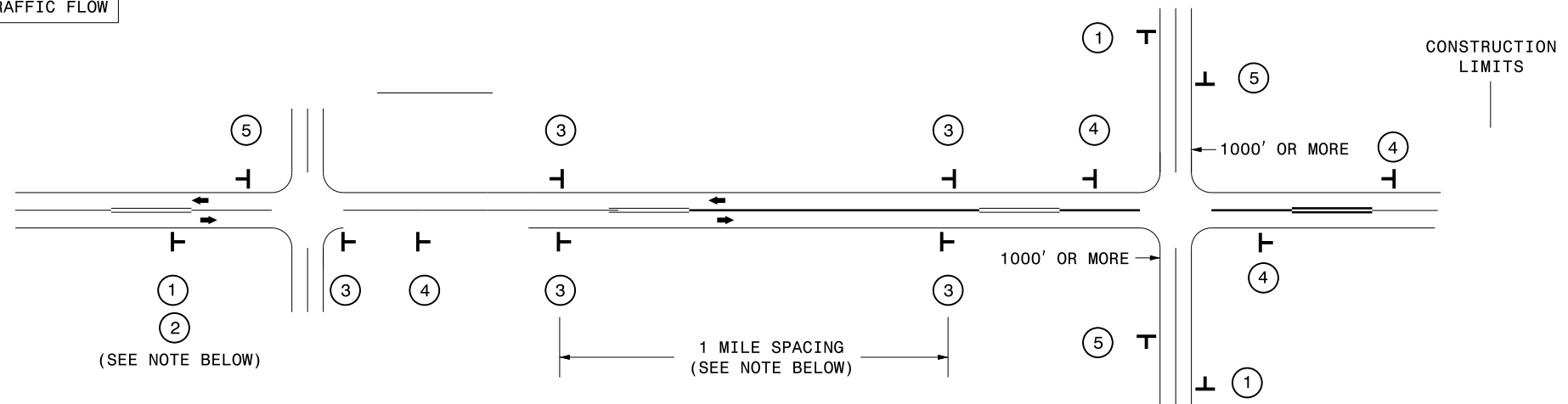

MAINLINE (-L-) SIGNING

-Y- LINE SIGNING

SIGNING NOTES AND PLACEMENT PER DIRECTION	<div style="display: flex; align-items: center; justify-content: center;"> <div style="border: 1px solid black; border-radius: 50%; width: 20px; height: 20px; margin-right: 5px; display: flex; align-items: center; justify-content: center;">1</div> <div> <p>PLACE 1000' PRIOR TO BEGINNING OF CONSTRUCTION LIMITS. ONLY USED ON -Y- LINES IF RESURFACING LIMITS EXTEND 1000' ALONG -Y- LINE.</p> </div> </div>
	<div style="display: flex; align-items: center; justify-content: center;"> <div style="border: 1px solid black; border-radius: 50%; width: 20px; height: 20px; margin-right: 5px; display: flex; align-items: center; justify-content: center;">2</div> <div> <p>W7-3aP 24" X 18"</p> </div> </div>
	<div style="display: flex; align-items: center; justify-content: center;"> <div style="border: 1px solid black; border-radius: 50%; width: 20px; height: 20px; margin-right: 5px; display: flex; align-items: center; justify-content: center;">3</div> <div> <p>SP 13107 48" X 48"</p> </div> </div>
	<div style="display: flex; align-items: center; justify-content: center;"> <div style="border: 1px solid black; border-radius: 50%; width: 20px; height: 20px; margin-right: 5px; display: flex; align-items: center; justify-content: center;">4</div> <div> <p>SP 13106 48" X 48"</p> </div> </div> <p style="font-size: small; margin-top: 5px;"> - THESE ARE FOR -Y- LINES THAT ARE "THROUGH" ROADWAYS. - DEAD END AND SUBDIVISION ROADS ARE NOT "THROUGH" ROADWAYS. - INSTALL 500' +/- FROM EACH -Y- LINE APPROACH AS SHOWN ABOVE. - FOR MULTIPLE -Y- LINES THAT ARE SEPARATED BY 0.25 MILES OR LESS, TREAT AS A SINGLE UNIT AND INSTALL WITHIN 500' OF EACH APPROACH. - A MAXIMUM OF 2 SIGN SETS PER MILE. DO NOT INSTALL WHEN -Y- LINES ARE WITHIN 0.5 MILES FROM "END ROAD WORK" SIGN. - FOR TEE INTERSECTIONS, INSTALL WITHIN 500' +/- OF THE INTERSECTION ALONG -L- LINE. </p>
<div style="display: flex; align-items: center; justify-content: center;"> <div style="border: 1px solid black; border-radius: 50%; width: 20px; height: 20px; margin-right: 5px; display: flex; align-items: center; justify-content: center;">5</div> <div> <p>PLACE 500' FOLLOWING THE END OF CONSTRUCTION LIMITS OR AS SHOWN WHEN WORK ENDS AT A 3-WAY TEE INTERSECTION.</p> </div> </div>	

NO REQUIRED STATIONARY SIGNING FOR THE FOLLOWING -Y- LINE CONDITIONS:

- 1) LESS THAN 1000' OF RESURFACING ALONG -Y- LINE
- 2) SUBDIVISION ROADS
- 3) DEAD END ROADS

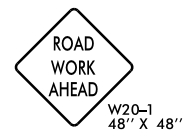

MAPS LESS THAN 2 MILES

FOR RESURFACING MAPS WITH CONSTRUCTION LIMITS LESS THAN 2 MILES IN LENGTH, NO STATIONARY SIGNS ARE REQUIRED. USE PORTABLE "ROAD UNDER CONSTRUCTION" OR "ROAD WORK AHEAD" SIGNS IN LIEU OF STATIONARY ADVANCE WARNINGS SIGNS.



ADVANCE WARNING SIGNS FOR RURAL AND SUBURBAN 2-LANE ROADWAY RESURFACING

21-APR-2021 15:27 C:\Users\j... Documents\June 2021 Resurfacing\Typicals Round 2.dgn dbhll AT DIV10-303607L

NOTES: LESS THAN 5' - 10' UNDISTURBED BUFFER FROM ROW, DITCHLINE, WATER FEATURE, OR DRAINAGE INLET, ADD BMP.

BMP OPTIONS: WATTLE OR SILT FENCE

STATE	PROJECT NO.	SHEET NO.	TOTAL SHEETS
N.C.	2021CPT.J0.I7.I0601 2021CPT.J0.I7.20601	EC-1	
F.A. PROJECT NO.			

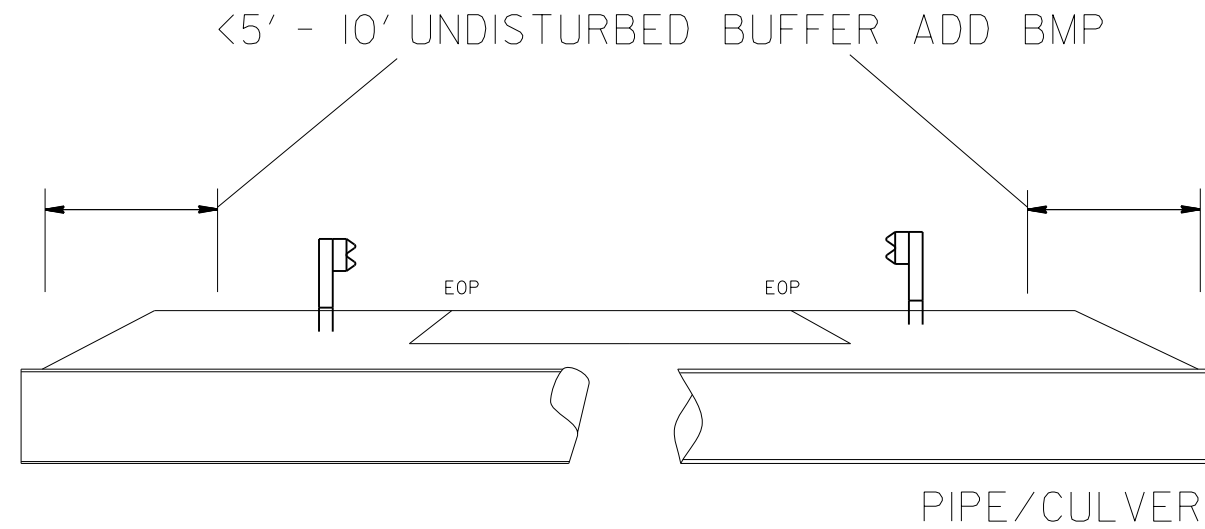

<5' - 10' UNDISTURBED BUFFER FROM JURISDICTIONAL FEATURE ADD BMP

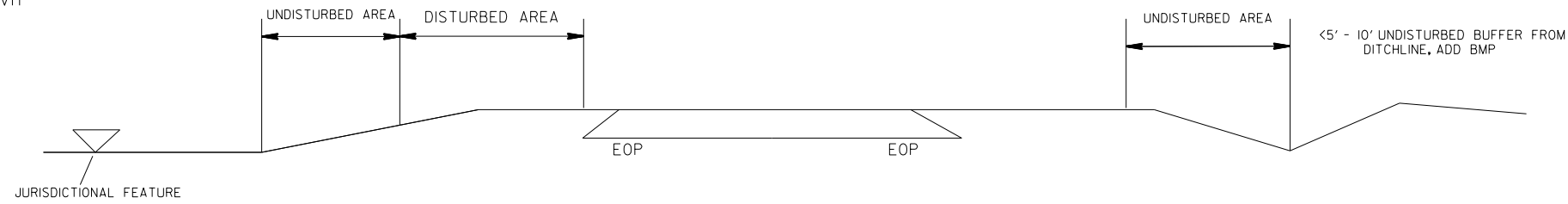

USE BMP'S IF SHOULDERS AND/OR FRONTSLOPES AND/OR DITCHLINE AND/OR BACKSLOPES ARE DISTURBED

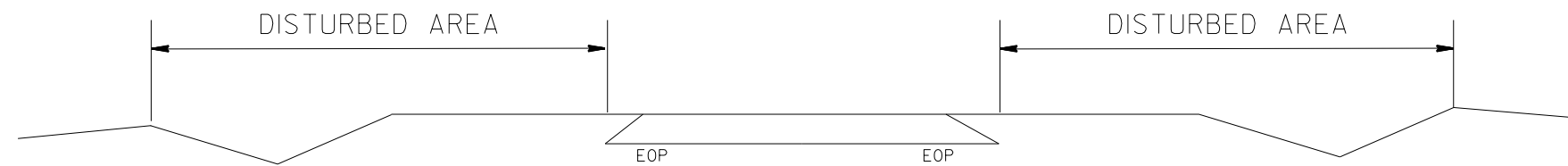

<5' - 10' UNDISTURBED BUFFER FROM INLET, ADD WATTLE

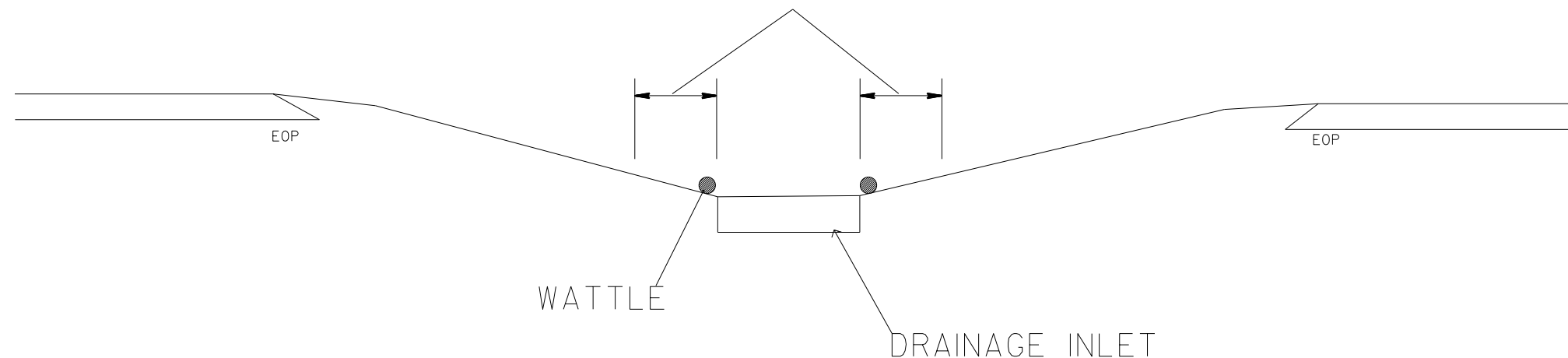

<i>EROSION CONTROL DETAIL</i>		
SCALE	-NA-	
DATE	1/21	
DWG. BY	AMO	
DESIGN BY	AMO	
APPROVED	CLA	
REVISIONS		

WATTLE WITH POLYACRYLAMIDE DETAIL

NOTES:

- USE MINIMUM 12 IN. DIAMETER EXCELSIOR WATTLE.
- USE 2 FT. WOODEN STAKES WITH A 2 IN. BY 2 IN. CROSS SECTION.
- INSTALL A MINIMUM OF 2 UPSLOPE STAKES AND 4 DOWNSLOPE STAKES AT AN ANGLE TO WEDGE WATTLE TO BOTTOM OF DITCH.
- PROVIDE STAPLES MADE OF 0.125 IN. DIAMETER STEEL WIRE FORMED INTO A U SHAPE NOT LESS THAN 12" IN LENGTH.
- INSTALL STAPLES APPROXIMATELY EVERY 1 LINEAR FOOT ON BOTH SIDES OF WATTLE AND AT EACH END TO SECURE IT TO THE SOIL.
- INSTALL MATTING IN ACCORDANCE WITH SECTION 1631 OF THE STANDARD SPECIFICATIONS.
- PRIOR TO POLYACRYLAMIDE (PAM) APPLICATION, OBTAIN A SOIL SAMPLE FROM PROJECT LOCATION, AND FROM OFFSITE MATERIAL, AND ANALYZE FOR APPROPRIATE PAM FLOCCULANT TO BE APPLIED TO EACH WATTLE.
- INITIALLY APPLY 3.5 OUNCES OF ANIONIC OR NEUTRALLY CHARGED POLYACRYLAMIDE (PAM) OVER WATTLE WHERE WATER WILL FLOW AND AFTER EVERY RAINFALL EVENT THAT IS EQUAL TO OR EXCEEDS 0.50 IN.

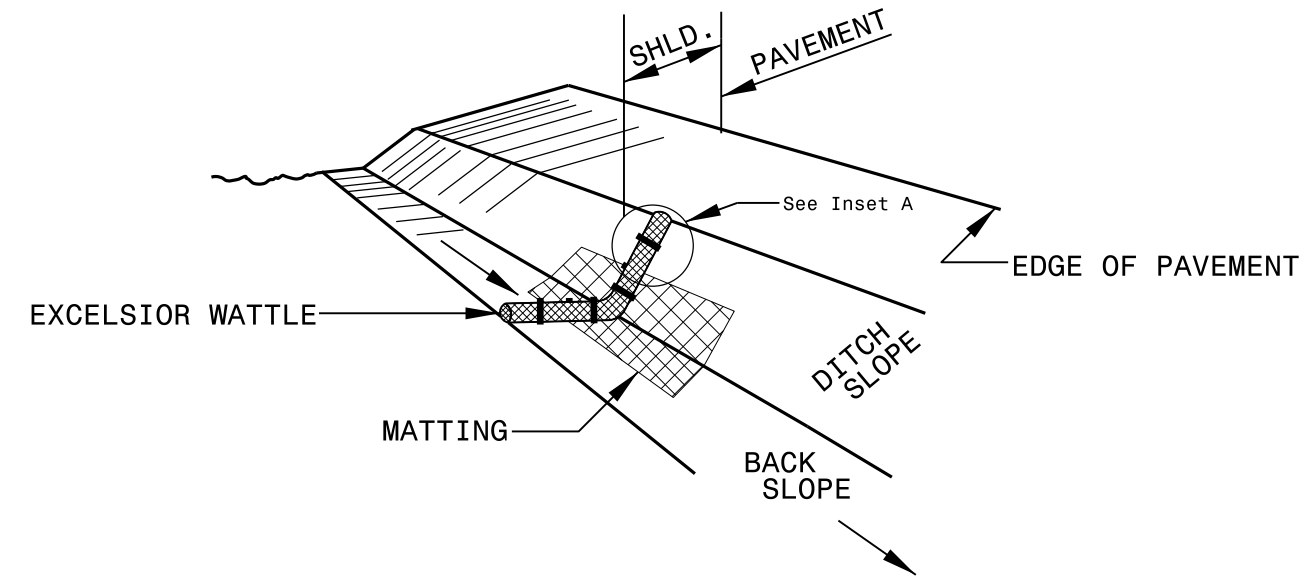

ISOMETRIC VIEW

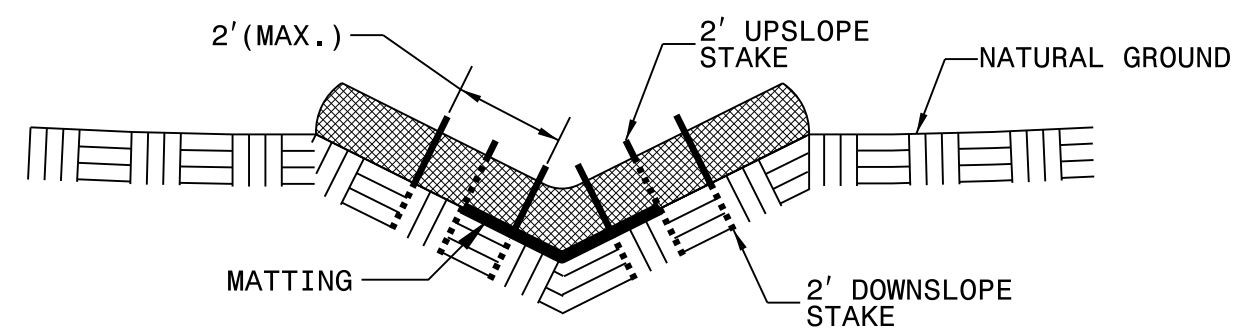

CROSS SECTION VEE DITCH

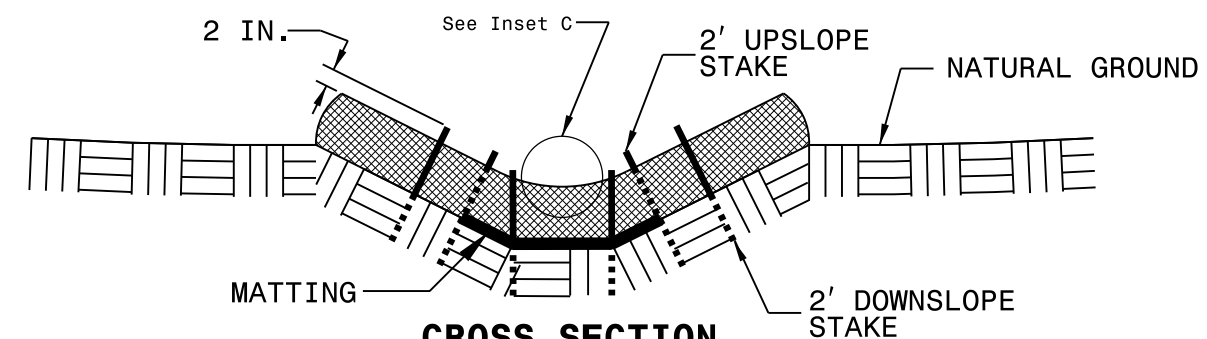

CROSS SECTION TRAPEZOIDAL DITCH

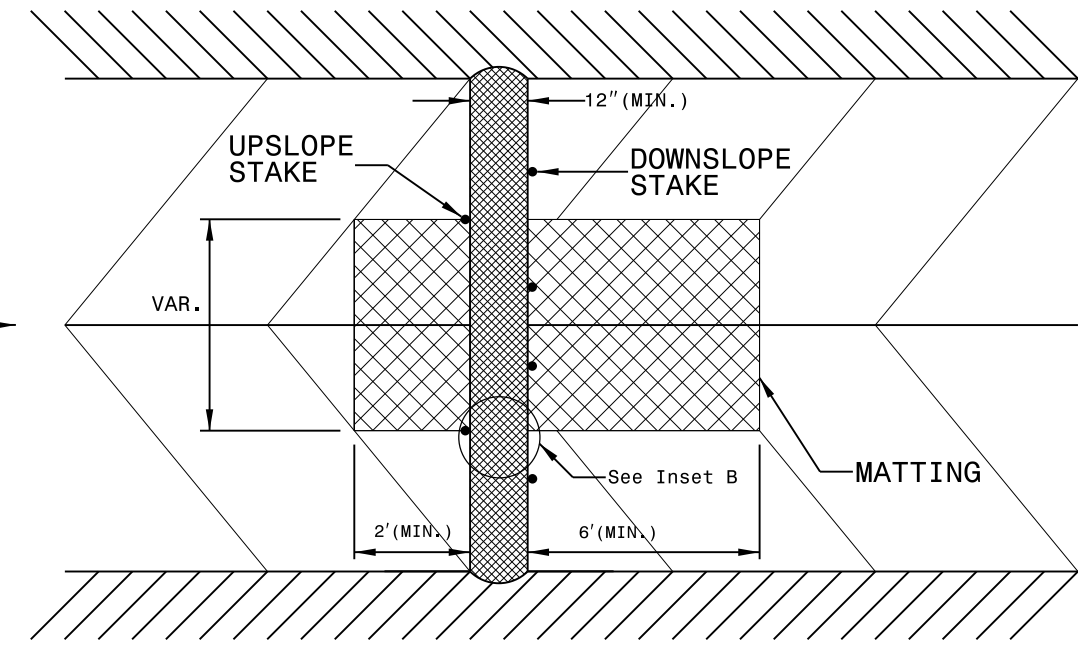
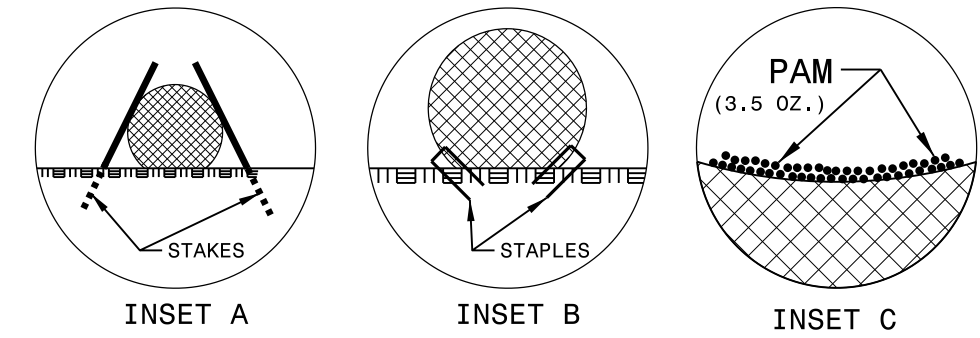

TOP VIEW